

ASSEMBLY INSTRUCTIONS

ANJUNA DESK

Please read instructions carefully. Remove all wrapping material, staples and packing straps from the carton. See Hardware and Furniture Parts List for guidance. Be sure you have all parts before you start assembling. Place all wooden furniture parts on a clean and flat soft surface, such as carpet or rug to prevent from being scratched.

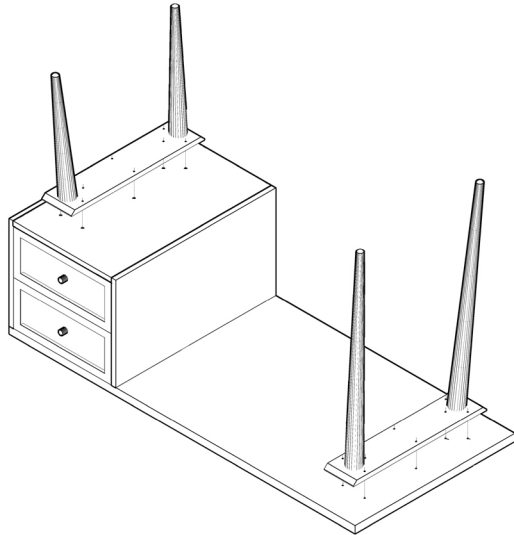

PARTS INCLUDED

1. TOP	:	1 Pc
2. LEG	:	2 Pcs

HARDWARE LIST

A. ALLEN KEY	:	1 Pcs
B. BOLT	:	16 Pc
C. WASHER	:	16 Pc



FOR ASSEMBLY

- First, check the content to make sure that nothing is missing.
- Sort out the parts and fittings as shown, assemble product step by step.
- It is preferable to rest the product on a soft surface to avoid damage during assembly.
- Do not over tighten screws and fittings.
- Re-tighten all screws and fittings periodically.

www.adairs.com.au
www.adairs.co.nz

STEP 1

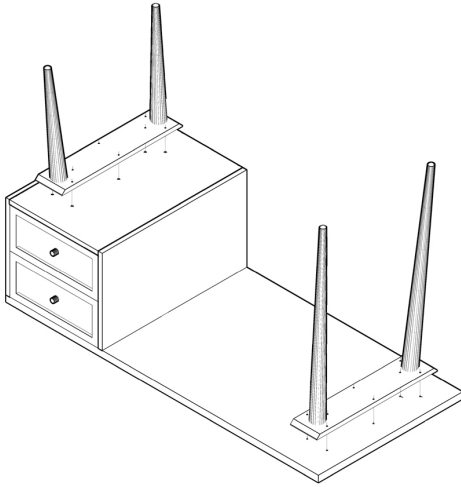

On a soft surface, such as a rug, turn the desk upside down. Align the 2 legs with the pre-drilled holes.

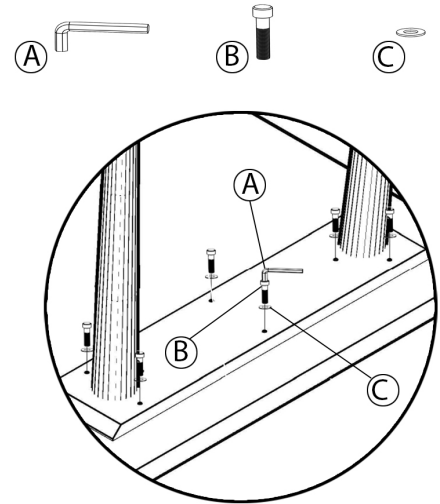

STEP 2

Tight all the screws

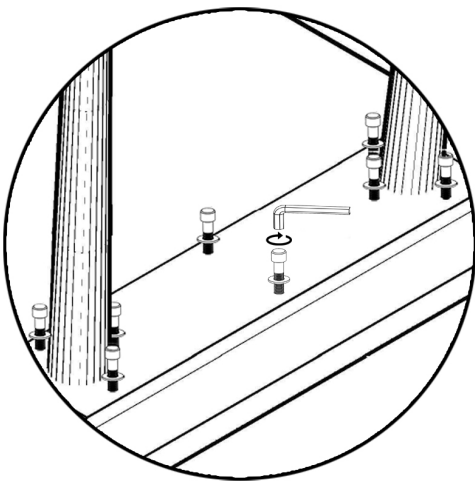

STEP 3

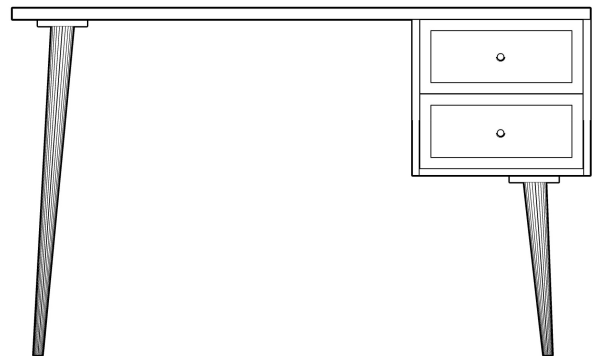

Warning: Two people are required to turn this unit upside down. NOTE this item is heavy and care should be taken when doing this. Turn the unit upside down. Your product is ready to use